Product Data Sheet

HMK12AA K3

Revision 1

(Variant Code 3)

1 Application

Application	Refrigerant	Expansion Device	Cooling Type
LBP	R600a	Capillary	Static

1.1 Application Conditions

Max. Ambient temp.¹	[°C]	43
Max. Steady discharge temp.²	[°C]	120
Max. Peak discharge temp.^{2, 5}	[°C]	135
Max. Steady condensing temp.³	[°C]	60
Max. Peak condensing temp.^{3, 5}	[°C]	70
Max. Winding temp.⁴	[°C]	130

¹...static

²...measured on discharge tube, 50 mm from the shell

³...measured in the middle of condenser

⁴...calculated out of the measured difference of resistance

⁵...max 5% of lifetime

Variant code according to Label; see General Product Documentation

2 Mechanical Data

Displacement	[cm³]	11,1
Net Weight¹	[kg]	8,4
Oil Type		mineral
Oil Charge	[ml]	165
Oil Viscosity	[cst]	7
Suction muffler		Semi direct
Free Gas Volume	[cm³]	1600
Length L	[mm]	194,2
Width W	[mm]	151,5
Height H	[mm]	167

¹...Compressor without accessories

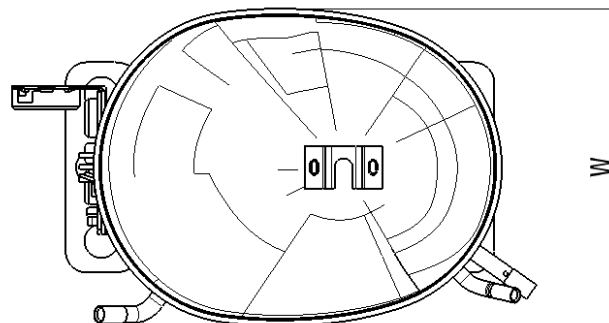
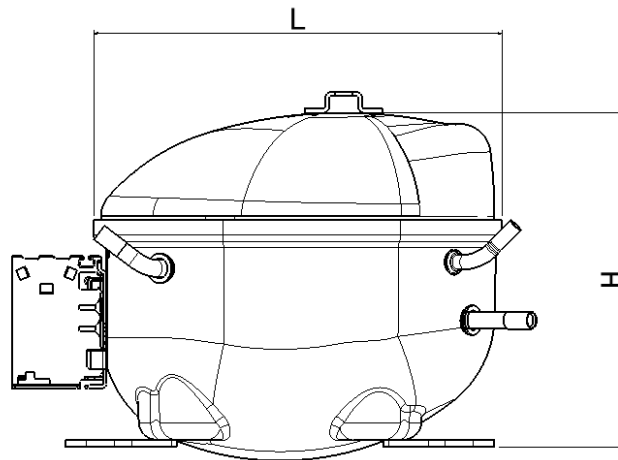

3 Electrical Data

Power supply	[V]	220 - 240
Voltage range ¹	[V]	187 - 264
Frequency	[Hz]	50
Phase	[ph]	1
Motor type		RSIR
Locked rotor current @ steady state	[A]	5,8
Max. Locked rotor current / measured after 4 sec	[A]	13,3 / 6,7
Main wind. Resistance @ 25°C	[Ω]	16,3
Start wind. Resistance @ 25°C	[Ω]	15,7

¹...Operating and starting (starting condition @ +43°C windings temperature, 3,5 barA equalized pressure)

All data measured according to EN 60335

3.1 Electrical Component Data

Terminal board		ECC
Starting device	Code	K100
PTC	Type	A
Run Capacitor	[μF]	-

3.2 Motor Protector

Motor Protector	BDG
Type	AE 72 FU x
Code	FP

4 Performance Data

4.1 Cooling Capacity, COP and Input Power

Performance Table Cooling Capacity @ ASHRAE / EN12900 (CECOMAF); 220V, 50Hz; [W]:

Evap. temp. [°C]		-35	-30	-25	-23,3	-20	-15	-10	
Condensing temp. @	ASHRAE [°C]	40	103,3	147,2	195,6	213,1	248,5	305,8	367,6
		45	102,0	143,8	190,9	208,1	243,2	300,7	363,4
		50	100,7	140,4	186,1	203,0	237,8	295,5	359,2
		55	99,4	137,0	181,4	198,0	232,5	291,0	355,0
		60	98,1	133,6	176,6	193,0	227,2	285,2	350,8
	EN12900 (CECOMAF) [°C]	C55	82,0	113,0	149,0	164,0	192,0	239,0	292,0

Performance Table COP without RC @ ASHRAE / EN12900 (CECOMAF); 220V, 50Hz; [W/W]:

Evap. temp. [°C]		-35	-30	-25	-23,3	-20	-15	-10	
Condensing temp. @	ASHRAE [°C]	40	1,19	1,44	1,69	1,78	1,94	2,19	2,44
		45	1,16	1,39	1,62	1,69	1,84	2,07	2,30
		50	1,13	1,33	1,54	1,61	1,75	1,95	2,16
		55	1,10	1,28	1,47	1,53	1,65	1,84	2,02
		60	1,06	1,23	1,39	1,45	1,55	1,72	1,88
	EN12900 (CECOMAF) [°C]	C55	0,90	1,06	1,20	1,26	1,36	1,51	1,66

Performance Table Input Power without RC @ ASHRAE / EN12900 (CECOMAF); 220V, 50Hz; [W]:

Evap. temp. [°C]		-35	-30	-25	-23,3	-20	-15	-10	
Condensing temp. @	ASHRAE [°C]	40	86,8	102,2	115,7	120,0	128,1	139,6	150,6
		45	88,0	103,7	118,2	122,9	131,9	145,1	158,0
		50	89,3	105,2	120,8	126,0	136,1	151,3	166,3
		55	90,7	107,0	123,7	129,0	140,9	158,2	175,7
		60	92,1	108,8	127,0	133,4	146,2	166,1	186,6
	EN12900 (CECOMAF) [°C]	C55	90,7	107,0	123,7	129,0	140,9	158,2	175,7

Test Conditions @ 220V/50Hz		ASHRAE	EN12900 (CECOMAF)
Evaporating temp.	[°C]	-23,3	-25
Condensing temp.	[°C]	55	55
Sub cooling temp.	[°C]	32	55
Suction temp.	[°C]	32	32
Ambient temp.	[°C]	32	32

Tolerance Range:

COP	± 5%
Cooling Capacity	± 5%

4.2 Rated current @ 55°C condensing temperature

Evaporating temperature	[°C]	-30	-23,3	-10
Rated current without RC	[A]	0,80	0,87	1,00

5 Reliability Tests

High Temperature CECOMAF GT4 – 002	passed
Wear CECOMAF GT4 – 003	passed
On – Off CECOMAF GT4 – 004	passed
Transport test ASTM D4728	passed