



Product Data Sheet

HMK95AT K3

Revision 1

1 Application

Application	Refrigerant	Expansion Device	Cooling Type
LBP	R600a	Capillary	Static

1.1 Application Conditions

Max. Ambient temp.¹	[°C]	43
Max. Steady discharge temp.²	[°C]	120
Max. Peak discharge temp.^{2, 5}	[°C]	135
Max. Steady condensing temp.³	[°C]	60
Max. Peak condensing temp.^{3, 5}	[°C]	70
Max. Winding temp.⁴	[°C]	130

¹...static

²...measured on discharge tube, 50 mm from the shell

³...measured in the middle of condenser

⁴...calculated out of the measured difference of resistance

⁵...max 5% of lifetime

Variant code according to Label; see General Product Documentation

ACC reserves the right to change the data without prior notice

2 Mechanical Data

Displacement	[cm ³]	9,6
Net Weight ¹	[kg]	8,4
Oil Type		mineral
Oil Charge	[ml]	165
Oil Viscosity	[cst]	7
Suction muffler		Semi direct
Free Gas Volume	[cm ³]	1600
Length L	[mm]	194,2
Width W	[mm]	151,5
Height H	[mm]	167

¹...Compressor without accessories

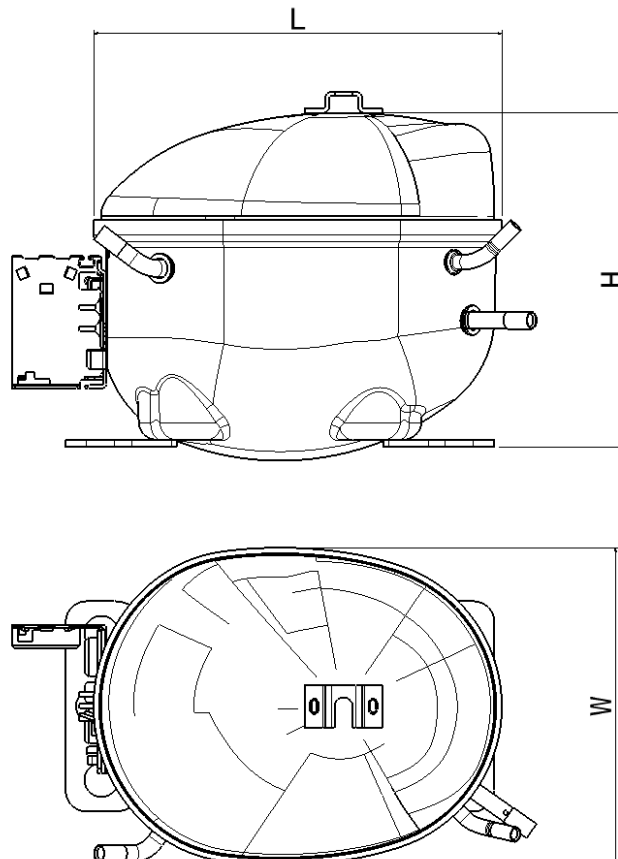

3 Electrical Data

Power supply	[V]	200 - 240
Voltage range ¹	[V]	170 - 264
Frequency	[Hz]	50
Phase	[ph]	1
Motor type		RSIR
Locked rotor current @ steady state	[A]	5,8
Max. Locked rotor current / measured after 4 sec	[A]	13,3 / 6,7
Main wind. Resistance @ 25°C	[Ω]	16,3
Start wind. Resistance @ 25°C	[Ω]	15,7

¹...Operating and starting (starting condition @ +43°C windings temperature, 3,5 barA equalized pressure)

All data measured according to EN 60335

3.1 Electrical Component Data

Terminal board		ECC
Starting device	Code	K100
PTC	Type	A
Run Capacitor	[μF]	-

3.2 Motor Protector

Motor Protector	BDG	Senbao
Type	AE 72 FU x	B86-120 x
Code	FP	MT

4 Performance Data

4.1 Cooling Capacity, COP and Input Power

Performance Table Cooling Capacity @ ASHRAE / EN12900 (CECOMAF); 220V, 50Hz; [W]:

Evap. temp. [°C]		-35	-30	-25	-23,3	-20	-15	-10	
Condensing temp. @	ASHRAE [°C]	40	96	124	160	174	204	256	316
		45	93	121	158	172	202	255	315
		50	89	118	155	169	200	253	314
		55	86	115	153	167	198	252	313
		60	82	112	150	165	196	250	312
	EN12900 (CECOMAF) [°C]	C55	71	95	126	138	163	207	257

Performance Table COP without RC @ ASHRAE / EN12900 (CECOMAF); 220V, 50Hz; [W/W]:

Evap. temp. [°C]		-35	-30	-25	-23,3	-20	-15	-10	
Condensing temp. @	ASHRAE [°C]	40	1,19	1,41	1,67	1,76	1,94	2,21	2,49
		45	1,16	1,36	1,60	1,69	1,84	2,11	2,37
		50	1,13	1,31	1,52	1,59	1,75	2,01	2,26
		55	1,10	1,25	1,46	1,53	1,68	1,91	2,16
		60	1,05	1,20	1,39	1,46	1,59	1,82	2,07
	EN12900 (CECOMAF) [°C]	C55	0,91	1,03	1,20	1,27	1,38	1,57	1,77

Performance Table Input Power without RC @ ASHRAE / EN12900 (CECOMAF); 220V, 50Hz; [W]:

Evap. temp. [°C]		-35	-30	-25	-23,3	-20	-15	-10	
Condensing temp. @	ASHRAE [°C]	40	81	88	96	99	105	116	127
		45	80	89	99	102	110	121	133
		50	79	90	102	106	114	126	139
		55	78	92	105	109	118	132	145
		60	78	93	108	113	123	137	151
	EN12900 (CECOMAF) [°C]	C55	78	92	105	109	118	132	145



Test Conditions @ 220V/50Hz		ASHRAE	EN12900 (CECOMAF)
Evaporating temp.	[°C]	-23,3	-25
Condensing temp.	[°C]	55	55
Sub cooling temp.	[°C]	32	55
Suction temp.	[°C]	32	32
Ambient temp.	[°C]	32	32

Tolerance Range:

COP ± 5%
Cooling Capacity ± 5%

4.2 Rated current @ 55°C condensing temperature

Evaporating temperature	[°C]	-30	-23,3	-10
Rated current without RC	[A]	0,70	0,78	0,88

5 Reliability Tests

High Temperature CECOMAF GT4 – 002	passed
Wear CECOMAF GT4 – 003	passed
On – Off CECOMAF GT4 – 004	passed
Transport test ASTM D4728	passed