

---

# **Product Data Sheet**

## **HKK12AT**

### **Revision 1**

## **1 Application**

<b>Application</b>	<b>Refrigerant</b>	<b>Expansion Device</b>	<b>Cooling Type</b>
LBP	R600a	Capillary	Static

### **1.1 Application Conditions**

<b>Max. Ambient temp.<sup>1</sup></b>	<b>[°C]</b>	43
<b>Max. Steady discharge temp.<sup>2</sup></b>	<b>[°C]</b>	120
<b>Max. Peak discharge temp.<sup>2, 5</sup></b>	<b>[°C]</b>	135
<b>Max. Steady condensing temp.<sup>3</sup></b>	<b>[°C]</b>	60
<b>Max. Peak condensing temp.<sup>3, 5</sup></b>	<b>[°C]</b>	70
<b>Max. Winding temp.<sup>4</sup></b>	<b>[°C]</b>	130

<sup>1</sup>...static

<sup>2</sup>...measured on discharge tube, 50 mm from the shell

<sup>3</sup>...measured in the middle of condenser

<sup>4</sup>...calculated out of the measured difference of resistance

<sup>5</sup>...max 5% of lifetime

Variant code according to Label; see General Product Documentation

## 2 Mechanical Data

Displacement	[cm <sup>3</sup> ]	11,1
Net Weight <sup>1</sup>	[kg]	9,3
Oil Type		mineral
Oil Charge	[ml]	165
Oil Viscosity	[cst]	5
Suction muffler		Semi direct
Free Gas Volume	[cm <sup>3</sup> ]	1560
Length L	[mm]	194,2
Width W	[mm]	151,5
Height H	[mm]	167

<sup>1</sup>...Compressor without accessories

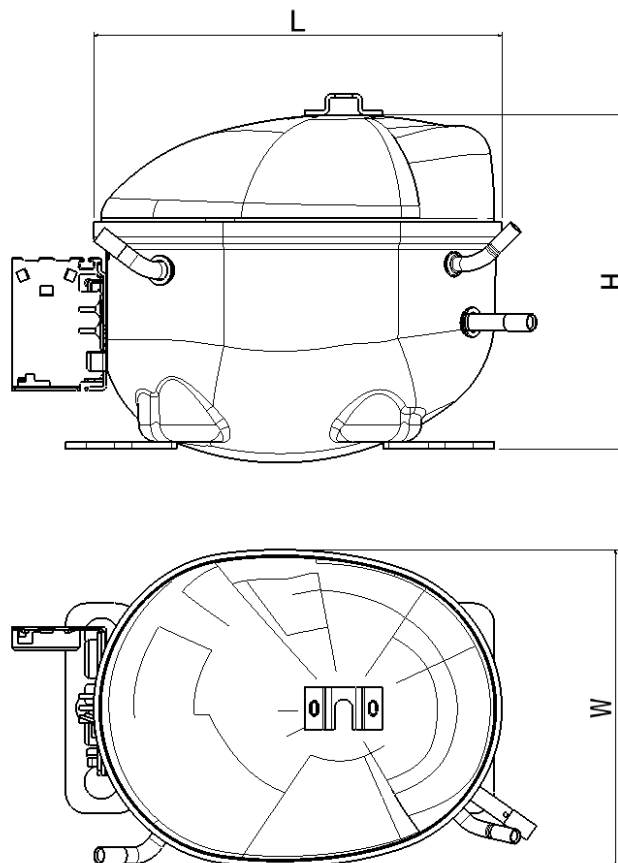

### 3 Electrical Data

Power supply	[V]	200 - 240
Voltage range <sup>1</sup>	[V]	170 – 264
Frequency	[Hz]	50
Phase	[ph]	1
Motor type		RSCR
Locked rotor current @ steady state	[A]	6,2
Max. Locked rotor current / measured after 4 sec	[A]	15,7 / 7,5
Main wind. Resistance @ 25°C	[Ω]	11,4
Start wind. Resistance @ 25°C	[Ω]	9,6

<sup>1</sup>...Operating and starting (starting condition @ +43°C windings temperature, 3,5 barA equalized pressure)

All data measured according to EN 60335

#### 3.1 Electrical Component Data

Terminal board		ECC
Starting device	Code	K100
PTC	Type	A
Run Capacitor	[μF]	4

#### 3.2 Motor Protector

Motor Protector	BDG
Type	AE 11 FQ
Code	FV

## 4 Performance Data

### 4.1 Cooling Capacity, COP and Input Power

Performance Table Cooling Capacity @ ASHRAE / (CECOMAF); 220V, 50Hz; [W]:

Evap. temp. [°C]		-35	-30	-25	-23,3	-20	-15	-10	
Condensing temp. @	ASHRAE [°C]	40	113	155	204	221	257	315	379
		45	108	150	197	215	250	309	374
		50	104	144	191	208	244	304	370
		55	100	139	185	202	238	298	365
		60	96	133	179	196	231	292	360
	EN12900 (CECOMAF) [°C]	C55	83	114	152	166	196	245	300

Performance Table COP with RC @ ASHRAE / (CECOMAF); 220V, 50Hz; [W/W]:

Evap. temp. [°C]		-35	-30	-25	-23,3	-20	-15	-10	
Condensing temp. @	ASHRAE [°C]	40	1,46	1,73	1,99	2,08	2,25	2,51	2,78
		45	1,40	1,65	1,90	1,98	2,15	2,40	2,65
		50	1,34	1,57	1,81	1,89	2,05	2,29	2,52
		55	1,27	1,50	1,72	1,80	1,95	2,17	2,40
		60	1,21	1,42	1,64	1,71	1,85	2,06	2,27
	EN12900 (CECOMAF) [°C]	C55	1,05	1,23	1,42	1,48	1,61	1,79	1,97

Performance Table Input Power with RC @ ASHRAE / (CECOMAF); 220V, 50Hz; [W]:

Evap. temp. [°C]		-35	-30	-25	-23,3	-20	-15	-10	
Condensing temp. @	ASHRAE [°C]	40	77	90	102	106	114	125	136
		45	77	91	104	108	116	129	141
		50	78	92	105	110	119	133	146
		55	79	93	107	112	122	137	152
		60	79	94	109	114	125	142	158
	EN12900 (CECOMAF) [°C]	C55	79	93	107	112	122	137	152

Test Conditions @ 220V/50Hz		ASHRAE	(CECOMAF)
Evaporating temp.	[°C]	-23,3	-25
Condensing temp.	[°C]	55	55
Sub cooling temp.	[°C]	32	55
Suction temp.	[°C]	32	32
Ambient temp.	[°C]	32	32

**Tolerance Range:**

COP ± 5%  
Cooling Capacity ± 5%

## 4.2 Rated current @ 55°C condensing temperature

Evaporating temperature	[°C]	-30	-23,3	-10
Rated current with RC	[A]	0,46	0,54	0,72

## 5 Reliability Tests

High Temperature CECOMAF GT4 – 002	passed
Wear CECOMAF GT4 – 003	passed
On – Off CECOMAF GT4 – 004	passed
Transport test ASTM D4728	passed